

**SC
190**

(Apr 2004)
(Rev.1
Apr 2019)
(Rev.2
Nov 2024)

**IACS Unified Interpretations (UI) SC 190 for
Application of SOLAS Regulation II-1/3-6 (Res
MSC.134(76)) and Technical Provisions on
Permanent Means of Access (Res MSC.133(76))**

Note:

1. This UI is to be applied by IACS Members and Associates when acting as a recognized organization, authorized by flag State Administrations to act on their behalf, unless otherwise advised, from 1 January 2005.
2. Rev.1 is to be applied by IACS Members from 1 July 2019.
3. Rev.2 is to be applied by IACS Members from 1 July 2025.

**SC
190
(cont)****SOLAS Reg.II-1/3-6**

1 Application

1.1 Except as provided for in paragraph 1.2, this regulation applies to **oil tankers** of 500 gross tonnage and over and bulk carriers, as defined in regulation IX/1, of 20,000 gross tonnage and over, constructed on or after 1 January 2005.

1.2 Oil tankers of 500 gross tonnage and over constructed on or after 1 October 1994 but before 1 January 2005 shall comply with the provisions of regulation II-1/12-2 adopted by resolution MSC.27(61).

Interpretation

Oil tankers:

Notwithstanding the definition of "oil tanker" in Reg.II-1/2.12, this regulation is only applicable to oil tankers having integral tanks for carriage of oil, which is contained in the definition of oil in Annex 1 of MARPOL 73/78. Independent oil tanks can be excluded.

Reg. II-1/3-6 is not normally applied to FPSO or FSO unless the Administration decides otherwise.

Technical Background

Permanent Means of Access (PMA) specified in the Technical Provision contained in Resolution MSC.133(76) is not specific whether it assumes application to integral cargo oil tanks or also to independent cargo oil tanks. ESP requirements of oil tankers have been established assuming the target cargo oil tanks are integral tanks. The PMA regulated under SOLAS Reg.II-1/3-6 is for overall and close-up inspections as defined in regulation IX/1. Therefore it is assumed that the target cargo oil tanks are those of ESP, i.e. integral cargo tanks.

Reg. II-1/3-6 is applicable to FPSO or FSO if they are subject to the ESP Code as amended.

Ref.

SOLAS Reg. IX/1 and the ESP Code as amended.

**SC
190
(cont)****SOLAS Reg.II-1/3-6**

- 2 Means of access to cargo and other spaces
- 2.1 Each space within **the cargo area** shall be provided with a permanent means of access to enable, throughout the life of a ship, overall and close-up inspections and thickness measurements of the ship's structures to be carried out by the Administration, the company, as defined in regulation IX/1, and the ship's personnel and others as necessary. Such means of access shall comply with the requirements of paragraph 5 and with the Technical provisions for means of access for inspections, adopted by the Maritime Safety Committee by resolution MSC.133(76), as may be amended by the Organization, provided that such amendments are adopted, brought into force and take effect in accordance with the provisions of article VIII of the present Convention concerning the amendment procedures applicable to the Annex other than chapter I.

Interpretation

Forepeak tanks on oil tankers and bulk carriers are to be addressed in the Technical Provisions as follows:

For fore peak tank with a depth of 6 m or more at the center line of the collision bulkhead a suitable means of access is to be provided for access to critical areas such as the underdeck structure, stringers, collision bulkhead and side shell structure.

Stringers of less than 6 m in vertical distance from the deck head or a stringer immediately above are considered to provide suitable access in combination with portable means of access.

In case the vertical distance between the deck head and stringers, stringers or the lowest stringer and the tank bottom is 6 m or more alternative means of access as defined in paragraph 9 of the Technical Provisions is to be provided.

Technical Background (Observation):

- 1) The third paragraph of Preamble of the Technical Provision contained in Annex of Resolution MSC.133(76) defines the ship structure referred to in SOLAS regulation II-1/3-6 on access to and within spaces in the cargo area of oil tankers and bulk carriers. Further it is defined that terms used in the Technical provisions have the same meaning as those defined in the 1974 SOLAS Conventions as amended, and in the ESP Code, as amended.
- 2) Definition of cargo area in SOLAS Reg. II-2/3.32 is cross-referenced in the ESP Code for oil tankers. However "cargo length area" is used for bulk carriers in the ESP Code for the relevant definition. This difference of terminology caused confusion for defining tanks or spaces, which are to be subject to the Technical provision.
- 3) Fore peak tanks have unique structural configurations and their means of access is addressed separately from other ballast tanks.

Ref.

SOLAS Reg. II-2/3.32 and the ESP Code.

SOLAS Reg.II-1/3-6

- 2.2 Where a permanent means of access may be susceptible to damage during normal cargo loading and unloading operations or where it is impracticable to fit permanent means of access, the Administration may allow, in lieu thereof, the provision of movable or portable means of access, as specified in the Technical provisions, provided that the means of attaching, rigging, suspending or supporting the portable means of access forms a permanent part of the ship's structure. All portable equipment shall be capable of being readily erected or deployed by ship's personnel.

Interpretation:

- 1) Movable means of access was envisioned in place of the elevated passageways for the permanent means of access to deck transverse. No specific design has been proposed that is considered appropriate. However a door should be kept open for an innovative approach in the future for developing alternative means of access suitable for the purposes:

Alternate means of access should include but not be limited to such devices as:

- .1 hydraulic arm fitted with a stable base
- .2 wire lift platform.
- .3 staging
- .4 Rafting
- .5 Robot arm or ROV
- .6 Rope access
- .7 Portable ladders more than 5 m long shall only be utilized if fitted with a mechanical device to secure the upper end of the ladder
- .8 other means of access, approved by and acceptable to the administration.

Means for safe operation and rigging such equipment to and from, and within these spaces, must be clearly demonstrated in the ~~PMA Manual~~ Ship Structure Access Manual.

- 2) Subject to acceptance as equivalent by the Administration, an unmanned robot arm, ROV's and dirigibles with necessary equipment of the permanent means of access for overall and close-up inspections and thickness measurements of the deck head structure such as deck transverses and deck longitudinals of cargo oil tanks and ballast tanks. Such robot arm and equipment are to be capable of:

- safe operation in ullage space in gas-free environment;
- introduction into the place from an access hole of the deck plating.

Technical Background

Elevated passageways in particular for access to deck transverses and upper part of transverse bulkheads and longitudinal bulkheads are subject to structural damages due to sloshing of liquid in the tank, corrosion and fatigue. Such damages would render the effective

**SC
190
(cont)**

use of the permanent means of access when needed for survey and inspection of under deck structure.

Innovative approaches in particular a development of robot in place of elevated passageways are encouraged and it is considered worthwhile to provide the functional requirement for the innovative approach.

SOLAS Reg.II-1/3-6

2.3 The construction and materials of all means of access and their attachment to the ship's structure shall be to the satisfaction of the Administration. The means of access shall be subject to survey prior to, or in conjunction with, its use in carrying out surveys in accordance with regulation I/10.

Interpretation:**Inspection**

The PMA arrangements, including portable equipment and attachments, are to be ~~periodically~~annually inspected by the crew or competent inspectors ~~as and when it is going to be used to confirm that the PMAs remain in serviceable condition~~ and the inspections are to be recorded in Part 2 of the Ship Structure Access Manual. In addition prior to any space examinations that utilized the permanent means of access, an inspection to confirm the condition of the permanent means of access is to be recorded for each space.

Procedures

1. Any authorised person using the PMA shall assume the role of inspector and check for obvious damage prior to using the access arrangements. Whilst using the PMA the inspector is to verify the condition of the sections used by close up examination of those sections and note any deterioration in the provisions. Should any damage or deterioration be found, the effect of such deterioration including loss of coating and wastage is to be assessed as to whether the damage or deterioration affects the safety for continued use of the access. Deterioration found that is considered to affect safe use is to be determined as "substantial damage" and measures are to be put in place to ensure that the affected section(s) are not to be further used prior to effective repair. Substantial damage is to be reported in Part 2 of the Ship Structure Access Manual.
2. Statutory survey of any space that contains PMA shall include verification of the continued effectiveness of the PMA in that space. Survey requirements of the PMA shall not be expected to exceed the scope and extent of the survey being undertaken. If the PMA is found deficient the scope of survey should be extended as found appropriate.
3. Records of all inspections are to be established with specific requirements detailed in the ships Safety Management System. The record is to be readily available to persons using the PMAs and it is recommended that a copy be attached to the Ship Structure Access Manual ~~PMA Manual~~. –The original records should include as a minimum the date of the inspection, the name and title of the inspector, a confirmation signature, the sections of PMA inspected, verification of continued serviceable condition or details of any deterioration or substantial damage found and repairs carried out. A file of permits issued should be maintained for verification. Inspection records of permanent means of access are to be made available to classification society surveyors prior to survey.

**SC
190
(cont)****Technical Background**

It is recognised that PMA is subject to deterioration in a long term due to corrosive environment and external forces from ship motions and sloshing of liquid contained in the tank, and mechanical damage in cargo hold. PMA therefore ~~should~~ is to be inspected at every opportunity of tank/space entry, but at a minimum annually. The above interpretation is to be contained in a section of the Ship Structure Access Manual ~~PMA Manual~~.

**SC
190
(cont)****SOLAS Reg.II-1/3-6****3 Safe access to cargo holds, cargo tanks, ballast tanks and other spaces**

3.1 Safe access* to cargo holds, cofferdams, ballast tanks, cargo tanks and other spaces in the cargo area shall be direct from the open deck and such as to ensure their complete inspection. Safe access to double bottom spaces may be from a pump-room, deep cofferdam, pipe tunnel, cargo hold, double hull space or similar compartment not intended for the carriage of oil or hazardous cargoes.

* Refer to the Recommendations for entering enclosed spaces aboard ships, adopted by the Organization by resolution A.864(20).

Interpretation

Access to a double side skin space of bulk carriers may be either from a topside tank or double bottom tank or from both.

Technical Background

Unless used other purposes, the double side skin space is to be designed as a part of a large U-shaped ballast tank and such space is to be accessed through the adjacent part of the tank, i.e. topside tank or double bottom/bilge hopper tank. Access to the double side skin space from the adjacent part rather than direct from the open deck is justified.

**SC
190
(cont)****SOLAS Reg.II-1/3-6**

3.2 Tanks, and subdivisions of tanks, having a length of 35 m or more shall be fitted with at least two access hatchways and ladders, as far apart as practicable. Tanks less than 35 m in length shall be served by at least one access hatchway and ladder. When a tank is subdivided by one or more swash bulkheads or similar obstructions which do not allow ready means of access to the other parts of the tank, at least two hatchways and ladders shall be fitted.

Interpretation

A cargo oil tank of less than 35 m length without a swash bulkhead requires only one access hatch.

**SC
190
(cont)****SOLAS Reg.II-1/3-6**

3.3 Each cargo hold shall be provided with at least two means of access as far apart as practicable. In general, these accesses should be arranged diagonally, for example one access near the forward bulkhead on the port side, the other one near the aft bulkhead on the starboard side.

Interpretation

N/A

Ref.

Paragraph 19 of Annex to MSC/Circ.686.

SOLAS Reg.II-1/3-6
4 Ship structure access manual

4.1 A ship's means of access to carry out overall and close-up inspections and thickness measurements shall be described in a Ship structure access manual approved by the Administration, an updated copy of which shall be kept on board. The Ship structure access manual shall include the following for each space in the cargo area:

- .1 plans showing the means of access to the space, with appropriate technical specifications and dimensions;
- .2 plans showing the means of access within each space to enable an overall inspection to be carried out, with appropriate technical specifications and dimensions. The plans shall indicate from where each area in the space can be inspected;
- .3 plans showing the means of access within the space to enable close-up inspections to be carried out, with appropriate technical specifications and dimensions. The plans shall indicate the positions of critical structural areas, whether the means of access is permanent or portable and from where each area can be inspected;
- .4 instructions for inspecting and maintaining the structural strength of all means of access and means of attachment, taking into account any corrosive atmosphere that may be within the space;
- .5 instructions for safety guidance when rafting is used for close-up inspections and thickness measurements;
- .6 instructions for the rigging and use of any portable means of access in a safe manner;
- .7 an inventory of all portable means of access; and
- .8 records of periodical inspections and maintenance of the ship's means of access.

Interpretation

As a minimum the English version should be provided

- The ship structure access manual is to contain at least the following two parts:

Part 1: Plans, instructions and inventory required by paragraphs 4.1.1 to 4.1.7 of Reg. II-1/3-6;

Part 2: Form of record of inspections and maintenance, and change of inventory of portable equipment due to additions or replacement after construction

- The part 1 of plans, instruction and inventory is to be approved by the Administration or the Classification Societies recognised by the Administration.
- The part 2 of record of inspections and maintenance, etc. is to be approved for its form only at new building.
- The following matters are to be addressed in the ship structure access manual:
 - 1) The access manual should clearly cover scope as specified in the regulations for use by crews, surveyors and port state control officers.
 - 2) Approval / re-approval procedure for Manual, i.e. any changes of the PMA, portable, movable or alternative means of access within the scope of the Regulation and the

**SC
190
(cont)**

Technical Provisions are subject to review and approval by the Administration or by the classification societies recognised by the Administration.

- 3) Verification of PMA be part of safety construction survey for continued effectiveness of the PMA in that space which is subject to the statutory survey.
- 4) Inspection of PMA by the crew and/or a competent inspector of the company as a part of regular inspection and maintenance.
(See Interpretation for paragraph 2.3 of SOLAS Reg.II-1/3-6)
- 5) Actions to be taken if PMA is found unsafe to use.
- 6) In case of use of portable equipment plans showing the means of access within each space indicating from where and how each area in the space can be inspected;

Model Section 5 "Inspection" of the access manual is to be developed addressing authorised use, permit to use system, inspection, and maintenance and repairs.

SOLAS Reg.II-1/3-6

4.2 For the purpose of this regulation “critical structural areas” are locations which have been identified from calculations to require monitoring or from the service history of similar or sister ships to be sensitive to cracking, buckling, deformation or corrosion which would impair the structural integrity of the ship.

Interpretation

1) Critical structural areas are to be identified by advanced calculation techniques for structural strength and fatigue performance, if available and feed back from the service history and design development of similar or sister ships.

2) Reference is to be made to the following publications for critical structural areas, where applicable:

- Oil tankers: Guidance Manual for Tanker Structures by TSCF;
- Bulk carriers: Bulk Carriers Guidelines for Surveys, Assessment and Repair of Hull Structure by IACS;
- Oil tankers and bulk carriers: The ESP Code as amended.

Technical Background

These documents contain the relevant information for the present ship types. However identification of critical areas for new double hull tankers and double side skin bulk carriers of improved structural design would have to be made by structural analysis at design stage if available.

**SC
190
(cont)****SOLAS Reg.II-1/3-6****5 General technical specifications**

5.1 For access through horizontal openings, hatches or manholes, the dimensions shall be sufficient to allow a person wearing a self-contained air-breathing apparatus and protective equipment to ascend or descend any ladder without obstruction and also provide a clear opening to facilitate the hoisting of an injured person from the bottom of the space. The minimum clear opening shall not be less than 600 mm x 600 mm. When access to a cargo hold is arranged through the cargo hatch, the top of the ladder shall be placed as close as possible to the hatch coaming. Access hatch coamings having a height greater than 900 mm shall also have steps on the outside in conjunction with the ladder.

Interpretation

The minimum clear opening of 600 mm x 600 mm may have corner radii up to 100 mm maximum. The clear opening is specified in MSC/Circ.686 to keep the opening fit for passage of personnel wearing a breathing apparatus. In such a case where as a consequence of structural analysis of a given design the stress is to be reduced around the opening, it is considered appropriate to take measures to reduce the stress such as making the opening larger with increased radii, e.g. 600 x 800 with 300 mm radii, in which a clear opening of 600 x 600 mm with corner radii up to 100mm maximum fits.

Technical Background

The interpretation is based upon the established Guidelines in MSC/Circ.686.

Ref.

Paragraphs 9 of Annex of MSC/Circ.686.

SC 190 (cont)

SOLAS Reg.II-1/3-6

5.2 For access through vertical openings, or manholes, in swash bulkheads, floors, girders and web frames providing passage through the length and breadth of the space, the minimum opening shall be not less than 600 mm x 800 mm at a height of not more than 600 mm from the bottom shell plating unless gratings or other foot holds are provided.

Interpretation

- 1) The minimum clear opening of not less than 600 mm x 800 mm may also include an opening with corner radii of 300 mm.
- 2) Subject to verification of easy evacuation of injured person on a stretcher the vertical opening 850 mm x 620 mm with wider upper half than 600 mm, while the lower half may be less than 600 mm with the overall height not less than 850 mm is considered acceptable alternative to the traditional opening of 600 mm x 800 mm with corner radii of 300 mm..

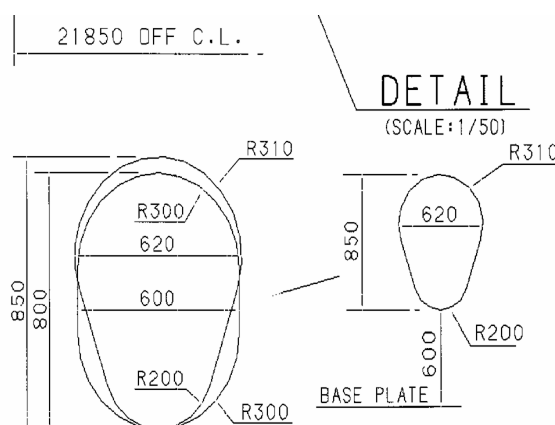

- 3) If a vertical opening is at a height of more than 600 mm steps and handgrips are to be provided. In such arrangement it should be demonstrated that an injured person can be easily evacuated.

Technical Background

The interpretation is based upon the established Guidelines in MSC/Circ.686 and an innovative design in consideration of human body to easily access through the opening.

Ref.

Paragraphs 11 of Annex of MSC/Circ.686.

**SC
190
(cont)****SOLAS Reg.II-1/3-6**

5.3 For oil tankers of less than 5,000 tonnes deadweight, the Administration may approve, in special circumstances, smaller dimensions for the openings referred to in paragraphs 5.1 and 5.2, if the ability to traverse such openings or to remove an injured person can be proved to the satisfaction of the Administration.”

Interpretation

N/A

**SC
190
(cont)****Technical Provision, Resolution MSC.133(76)****Preamble**

It has long been recognised that the only way of ensuring that the condition of a ship's structure is maintained to conform with the applicable requirements is for all its components to be surveyed on a regular basis throughout their operational life so as to ensure that they are free from damage such as cracks, buckling or deformation due to corrosion, overloading or contact damage and that thickness diminution is within established limits. The provision of suitable means of access to the hull structure for the purpose of carrying out overall and close-up surveys and inspections is essential and such means should be considered and provided for at the ship design stage.

Ships should be designed and built with due consideration as to how they will be surveyed by flag State inspectors and classification society surveyors during their in-service life and how the crew will be able to monitor the condition of the ship. Without adequate access, the structural condition of the ship can deteriorate undetected and major structural failure can arise. A comprehensive approach to design and maintenance is required to cover the whole projected life of the ship.

Interpretation

N/A

**SC
190
(cont)****Technical Provision, Resolution MSC.133(76)****Preamble****3rd Paragraph**

In order to address this issue, the Organization has developed these Technical provisions for means of access for inspections, intended to facilitate close-up inspections and thickness measurements of the ship's structure referred to in SOLAS regulation II-1/3-6 on Access to and within spaces in the cargo area of oil tankers and bulk carriers.

Interpretation

To refer to the observation of "cargo area" in Reg. II-1/3-6.2.1.

**SC
190
(cont)****Technical Provision, Resolution MSC.133(76)****Definitions**

Terms used in the Technical provisions have the same meaning as those defined in the 1974 SOLAS Convention, as amended, and in the ESP Code, as amended.

Interpretation

The following definitions other than those contained in the ESP Code have been used for the interpretations:

1. Rung means the step of vertical ladder or step on the vertical surface.
2. Tread means the step of inclined ladder, or for vertical access opening.
3. Flight of an inclined ladder means the actual stringer length of an inclined ladder. For vertical ladders, it is the distance between the platforms.
4. Stringer means
 - a. the frame of a ladder; or
 - b. the stiffened horizontal plating structure fitted on side shell, transverse bulkheads and/or longitudinal bulkheads in the space. For the purpose of ballast tanks of less than 5 m width forming double side spaces, the horizontal plating structure is credited as a stringer that is installed to secure continuous 600 mm or more in width past side longitudinals or stiffeners on side shell or longitudinal bulkhead. Openings in the stringer plating, if any, are to be arranged with safe guard rails or grid cover for not to impair safe passage on the stringer or safe access to each transverse web.
5. vertical ladder means the ladder of which inclined angle is 70 degrees and over up to 90 degrees. Vertical ladder shall not be skewed by more than 2 degrees.
6. Overhead obstructions mean the deck or stringer structure including stiffeners above the means of access.
7. Distance below the deck head means the distance below the plating.

Technical Background

The definition of stringer as the horizontal structural member is defined in the context of Section 2 (Wing water ballast tanks of less than 5 m width forming double side space and their bilge hopper sections) of Table 1 – Means of access for oil tankers. This section is also referred to by paragraph 2.8 (Double skin side tanks) of Table 2 – Means of access for bulk carriers.

**SC
190
(cont)****Technical Provision, Resolution MSC.133(76)**

1 Structural members subject to the close-up inspections and thickness measurements of the ship's structure referred to in SOLAS regulation II-1/ 3-6, except those in double bottom spaces, shall be provided with a permanent means of access to the extent as specified in table 1 and table 2, as applicable. For oil tankers and wing ballast tanks of ore carriers, rafting may be used in addition to the specified permanent means of access, provided that the structure allows for its safe and effective use.

Interpretation

The permanent means of access to a space can be credited for the permanent means of access for inspection.

For oil tankers and wing ballast tanks of ore carriers, approved alternative methods may be used in combination with the fitted permanent means of access, provided that the structure allows for its safe and effective use.

Technical Background

The Technical Provisions specify means of access to a space and to hull structure for carrying out overall and close up surveys and inspections. Requirements of PMA to hull structure may not always be suitable for access to a space. However if the PMA for access to a space can also be used for the intended surveys and inspections such PMA can be credited for the PMA for use for surveys and inspections.

**SC
190
(cont)****Technical Provision, Resolution MSC.133(76)**

2 Elevated passageways, where fitted, shall have a minimum width of 600 mm and be provided with toe boards not less than 150 mm high and guard rails over both sides of their entire length. Sloping structure providing part of the access shall be of a non-skid construction. Guard rails shall be 1,000 mm in height and consist of a rail and intermediate bar 500 mm in height and of substantial construction. Stanchions shall be not more than 3 m apart.

Interpretation

- 1) Guardrail arrangement specified by the provisions of paragraphs (2) and (3) of Reg.25 in ICLL, i.e. guardrails of 1.0 m in height having intermediate rails such that lowest course is not more than 230mm with a 50 mm toe board and other courses are not more than 380mm is to be considered as an alternative to the toe boards and the guard rails specified in TP.2.
- 2) Permanent means of access of the following configuration is to be considered as an alternative to the elevated passageways: The permanent means of access is integrated in the structure by means of wide longitudinals, on stiffened structural surfaces is to have a minimum clear width of 600 mm. The clear width may be minimum 450 mm for going around vertical webs. Guardrails is to be fitted over the open side of their entire length and is to be of substantial construction, 1,000 mm in height and consist of a rail and an intermediate bar at 500 mm in height. Stanchions is to be not more than 3 m apart
- 3) Height of toe board is to be measured from the surface of the passage way.
- 4) Slopping structures are structures that are sloped by 5 or more degrees from horizontal plane when a ship is in upright position at even-keel.
- 5) Guard rails are to be fitted on the open side. For stand alone passageways guard rails are to be fitted on both sides of these structures.
- 6) Discontinuous handrails and toe boards in way thereof are allowed provided the gap for both does not exceed 50 mm. The maximum distance between the adjacent stanchions across the handrail gaps is to be 350 mm.
- 7) Non-skid construction is such that the surface on which personnel walks provides sufficient friction to the sole of boots even the surface is wet and covered with thin sediment.
- 8) "Substantial construction" is taken to refer to the as designed strength as well as the residual strength during the service life of the vessel. Durability of passageways together with guard rails should be ensured by the initial corrosion protection and inspection and maintenance during services.
- 9) For guard rails, use of alternative materials such as GRP should be subject to compatibility with the liquid carried in the tank. Non-fire resistant materials should not be used for means of access to a space with a view to securing an escape route at a high temperature.

**SC
190**
(cont)

10) Requirements for resting platforms placed between ladders are equivalent to those applicable to elevated passageways.

Technical Background

1) The toe board fitted to the wide face plate of a deck transverse for an elevated passageway would easily trap sludge and sediment, which would likely cause difficulty for a safe use of the passageway. The interpretation in items 1) and 2) above provides practical solution for a safe use of the permanent means of access.

Ref.

Paragraph 10 of Annex to MSC/Circ.686

**SC
190
(cont)****Technical Provision, Resolution MSC.133(76)**

3 Access to elevated passageways and vertical openings from the ship's bottom shall be provided by means of easily accessible passageways, ladders or treads. Treads shall be provided with lateral support for the foot. Where the rungs of ladders are fitted against a vertical surface, the distance from the centre of the rungs to the surface shall be at least 150 mm. Where vertical manholes are fitted higher than 600 mm above the walking level, access shall be facilitated by means of treads and hand grips with platform landings on both sides.

Interpretation

If the vertical opening is at a height of more than 600 mm steps and handgrips are to be provided. In such an arrangement it should be demonstrated that an injured person can be easily evacuated.

**SC
190
(cont)****Technical Provision, Resolution MSC.133(76)**

4 Tunnels passing through cargo holds shall be equipped with ladders or steps at each end of the hold so that personnel may easily cross such tunnels.

Interpretation

the tunnel would mean a shaft tunnel of a ship having a cargo hold aft of engine room.

Technical Provision, Resolution MSC.133(76)

5 Permanent ladders, except for vertical ladders, which are fitted on vertical structures for close-up inspection or thickness measurement, shall be inclined at an angle of less than 70°. There shall be no obstructions within 750 mm of the face of the inclined ladder, except that in way of an opening this clearance may be reduced to 600 mm. The flights of ladders shall not be more than 9 m in actual length. Resting platforms of adequate dimensions shall be provided. Ladders and handrails shall be constructed of steel or equivalent material of adequate strength and stiffness and securely attached to the tank structure by stays. The method of support and length of stay shall be such that vibration is reduced to a practical minimum. In cargo holds, ladders shall be designed and arranged so that the risk of damage from cargo handling gear is minimized.

PMA for access to ballast tanks, cargo tanks and spaces:**For oil tankers:**

- 1) Tanks and subdivisions of tanks having a length of 35 m or more: Inclined ladder or ladders are to be used for one of the access hatchways. For another, a vertical ladder may be used for access to a space where the vertical distance is 6 m or less between the deck and the stringer, between stringers, or between the deck or a stringer and the bottom of the space immediately below the entrance. In such a case where the vertical distance is more than 6 m but not exceeding 9 m vertical ladders comprising one or more ladder linking platforms spaced not more than 6 m apart vertically and displaced to one side of the ladder may also be used for this purpose. The uppermost, entrance section from deck, of the vertical ladder of a tank should be vertical for 2.5 m measured clear of the overhead obstructions and comprises a ladder linking platform. It should be displaced to one side of a vertical ladder. However, the vertical ladder may be down to 1.6 m to 3 m below deck structure if it lands on longitudinal or athwartship permanent means of access fitted within that range.
- 2) For the other access hatchway of the tank or subdivisions of tanks, an inclined ladder or combination of ladders are to be used for access to the space. The uppermost, entrance section from deck, of the ladder should be vertical for 2.5 m to clear an overhead obstructions and comprises a landing platform and continued with an inclined ladder. However, the vertical ladder may be down to 1.6 m to 3 m below deck structure if it lands on longitudinal or athwartship permanent means of access fitted within that range. The flights of the inclined ladders are not to be more than 9 meters in actual length and normally not more than 6 m in vertical height. The lowermost section of the ladders may be vertical for the vertical distance not exceeding 2.5 m.
- 3) Tanks less than 35 m in length and served by one access hatchway an inclined ladder or combination of ladders are to be used to the space as specified in 2) above.
- 4) In double hull spaces of less than 2.5 m width the access to the space may be by means of vertical ladders that comprises one or more ladder linking platforms spaced not more than 6 m apart vertically and displace to one side of the ladder. The uppermost, entrance section, of the vertical ladder of a tank from deck should be vertical for 2.5 m measured clear of the overhead obstructions and comprises a ladder linking platform. However, the

**SC
190
(cont)**

vertical ladder may be down to 1.6 m to 3 m below overhead structure if it lands on longitudinal or athwartship permanent means of access fitted within that range. Adjacent sections of ladder should be laterally offset from each other by at least the width of the ladder. (Paragraph 20 of MSC/Circ.686)

- 5) Access from deck to a double bottom space may be of vertical ladders through a trunk. The vertical distance from deck to a resting platform, between resting platforms or a resting platform and the tank bottom is not be more than 6 m unless otherwise approved by the Administration.

For bulk carriers:

- 1) A vertical ladder may be used as a means of access to topside tanks, where the vertical distance is 6 m or less between the deck and the longitudinal means of access in the tank, the stringer or the bottom of the space immediately below the entrance. The uppermost, entrance section from deck, of the vertical ladder of the tank should be vertical for 2.5 m measured clear of the overhead obstructions and comprises a ladder linking platform unless landing on the longitudinal means of access, the stringer or the bottom,
- 2) Unless allowed in 1) above, an inclined ladder or combination of ladders are to be used for access to a tank or a space where the vertical distance is greater than 6 m between the deck and a stringer immediately below the entrance, between stringers, or between the deck or a stringer and the bottom of the space immediately below the entrance.
- 3) In case of paragraph 2) above the uppermost, entrance section from deck, of the ladder should be vertical for 2.5 m clear of the overhead obstructions and connected to a landing platform and continued with an inclined ladder. The flights of the inclined ladders are not to be more than 9 meters in actual length. The height of the inclined ladder is normally not to be more than 6m. The lowermost section of the inclined ladder may be vertical for a vertical distance not exceeding 2.5 m.
- 4) In double side skin spaces of less than 2.5 m width between top side tanks and bilge hopper tanks the access to the space may be by means of vertical ladders that comprises one or more ladder linking platforms spaced not more than 6 m apart vertically and displace to one side of the ladder. Adjacent sections of ladder should be laterally offset from each other by at least the width of the ladder. (Paragraph 20 of MSC/Circ.686)

PMA for inspection of the vertical structure of oil tankers and of double side skin spaces of bulk carriers:

- 1) Vertical ladders provided for means of access to the space may be used for access for inspection of the vertical structure
- 2) Vertical ladders that are fitted on vertical structures for inspection should comprise one or more ladder linking platforms spaced not more than 6 m apart vertically and displace to one side of the ladder. Adjacent sections of ladder should be laterally offset from each other by at least the width of the ladder. (Paragraph 20 of MSC/Circ.686)

**SC
190
(cont)****Obstruction distances**

The minimum distance between the inclined ladder face and obstructions, i.e. 750 mm and, in way of openings, 600 mm specified in TP.5 is to be measured perpendicular to the face of the ladder.

Use of spiral ladders

A spiral ladder is considered acceptable as an alternative for inclined ladders. In this regard it is noted that the uppermost 2.5m may continue to be comprised of the spiral ladder and need not change over to vertical ladders. In such a case where it is not practicable to continue the spiral ladder within the uppermost 2.5m underneath the upper entrance such as cross deck or bottom or upper stool, a vertical ladder is to be used for that part. The design is to be according to recognised International or National standards that are acceptable to the Administration.

Technical Background

- It is a common practice to use a vertical ladder from deck to the first landing to clear overhead obstructions before continuing to an inclined ladder or a vertical ladder displaced to one side of the first vertical ladder.
- As provided in paragraph 20 of Annex to MSC/Circ.686, vertical ladders are to comprise one or more ladder linking platforms spaced not more than 6 m apart vertically. Therefore for the access to a space with the vertical distance not more than 6m between stringers or the lowest stringer and the bottom a vertical ladder can also be used safely.
- For narrow double hull spaces, i.e. less than 2.5 m width inclined ladders or vertical ladders may be installed with linking platforms spaced not more than 6 m apart.

Ref.

For vertical ladders: Paragraph 20 of Annex to MSC/Circ.686

For spiral stairways: AMSA Marine Orders Part 32, Appendix 17:

Technical Provision, Resolution MSC.133(76)

6 The width of ladders between stringers shall not be less than 400 mm. The treads shall be equally spaced at a distance apart, measured vertically, of between 250 mm and 300 mm. When steel is used, the treads shall be formed of two square bars of not less than 22 mm by 22 mm in section, fitted to form a horizontal step with the edges pointing upward. The treads shall be carried through the side stringers and attached thereto by double continuous welding. All sloping ladders shall be provided with handrails of substantial construction on both sides fitted at a convenient distance above the treads.

Interpretation

- 1) Vertical height of handrails is not to be less than [890] mm from the center of the step and two course handrails are to be provided.
- 2) The requirement of two square bars for treads specified in TP 6 is based upon the specification of construction of ladders in paragraph 3(e) of Annex 1 to Resolution A.272(VIII), which addresses inclined ladders. TP.3 allows for single rungs fitted to vertical surfaces, which is considered for a safe grip. For vertical ladders, when steel is used, the treads should be formed of single square bars of not less than 22 mm by 22 mm for the sake of safe grip.
- 3) The width of inclined ladders for access to a cargo hold is to be at least 450 mm to comply Australian AMSA Marine Orders Part 32, Appendix 17.
- 4) The width of inclined ladders other than an access to a cargo hold is to be not less than 400 mm.
- 5) The minimum width of vertical ladders is to be 350 mm and the pitch of the treads is to be equal and is to be between 250 mm and 300 mm.
- 6) A minimum climbing clearance in width is to be 600 mm other than the ladders placed between the hold frames.
- 7) The vertical ladders should be secured at intervals not exceeding 2.5 m apart to prevent vibration.

Technical Background

- TP.6 is a continuation of TP.5, which addresses inclined ladders. Interpretations for vertical ladders are needed based upon the current standards of IMO, AMSA or the industry.
- Interpretations 2) and 5) address vertical ladders based upon the current standards.
- Double square bars for treads become too large for a grip for vertical ladders and single treads facilitate a safe grip.

**SC
190**
(cont)

- Interpretation 7) is introduced consistently with the requirement and the interpretation of TP 3.

Ref.

- Annex 1 to Resolution A.272(VIII)
- Australian AMSA Marine Orders Part 32, Appendix 17
- ILO Code of Practice "Safety and Health in Dockwork" – Section 3.6 Access to Ship's Holds

**SC
190**
(cont)

Technical Provision, Resolution MSC.133(76)

7 No free-standing portable ladder shall be more than 5 m long.

Interpretation

N/A

**SC
190
(cont)****Technical Provision, Resolution MSC.133(76)**

8 Portable ladders more than 5 m long may only be utilized if fitted with a remotely controlled mechanical device to secure the upper end of the ladder.

Interpretation

A mechanical device such as hooks for securing at the upper end of a ladder is considered as an alternative to a remotely controlled mechanical device stipulated in TP 8 if a movement fore/aft and sideways can be prevented at the upper end of the ladder.

Technical Background

Innovative design is to be accepted if it fits for the functional requirement with due consideration for safe use.

**SC
190
(cont)****Technical Provision, Resolution MSC.133(76)**

- 9 Movable means of access includes such devices as:
- .1 hydraulic arm fitted with a stable base and with local control at the safety cage. The operational conditions should be in accordance with applicable safety requirements of the manufacturer; and
 - .2 wire lift platform.

Interpretation

Alternative means of access includes but not limited to such devices as:

- .1 hydraulic arm fitted with a stable base;
- .2 wire lift platform.
- .3 staging
- .4 Rafting
- .5 Robot arm or ROV
- .6 Rope access
- .7 Portable ladders more than 5 m long may only be utilized if fitted with a mechanical device to secure the upper end of the ladder
- .8 other means of access, approved by and acceptable to the Administration.

Technical Background

Innovative design is to be accepted if it fits for the functional requirement with due consideration for safe use.

**SC
190
(cont)****Technical Provision, Resolution MSC.133(76)**

- 10 For bulk carriers, access ladders to a cargo hold shall be:
- .1 where the vertical distance between the upper surface of adjacent decks or between deck and the bottom of the cargo space is not more than 6 m, either a vertical ladder or an inclined ladder; and
 - .2 where the vertical distance between the upper surface of adjacent decks or between deck and the bottom of the cargo space is more than 6 m, an inclined ladder or ladders, except the uppermost 2.5 m of a cargo space measured clear of overhead obstructions and the lowest 6 m may have vertical ladders, provided that the vertical extent of the inclined

Interpretation

- 1) Either a vertical or an inclined ladder or a combination of them may be used for access to a cargo hold where the vertical distance is 6 m or less from the deck to the bottom of the cargo hold.
- 2) An inclined ladder or a combination of ladders are to be used for access to a cargo hold where the vertical distance is more than 6 m. The uppermost, entrance section, of the ladder directly exposed to a cargo hold should be vertical for 2.5 m measured clear of overhead obstructions, connected to a landing platform and continued with an inclined ladder system. The flights of the inclined ladders are not to be more than 9 meters in actual length. The lowermost section of the combination of ladders may be vertical for the vertical distance not exceeding 6 m, provided that the vertical extent of the inclined ladder or ladders connecting the vertical ladders is not less than 2.5 m.
- 3) Spiral stairways are considered acceptable as an alternative for providing access to the cargo holds. In this regard it is noted that the uppermost 2.5m and lowermost 6m may continue to be comprised of the spiral stairways and need not change over to vertical ladders. In such a case where it is not practicable to continue the spiral stairways within the uppermost 2.5m underneath the upper entrance such as cross deck or bottom or upper stool, a vertical ladder may be used for that part. The design is to be according to recognised International or National standards that are acceptable to the Administration.
- 4) One of the two means of access required by SOLAS Reg. 3-6-3.3 for each cargo hold is to comply with paragraph 10.2 of the technical Provisions.

Technical Background for items 4) and 5)

Present bulk carriers have two independent means of access to a cargo hold, the design of which is in compliance with the Australian requirements. Practical problems have been envisioned for inclined ladders in existing bulk carriers. Inclined ladders including spiral ladders are more prone to cargo damages than staggered vertical ladders unless properly protected by bulkheads. It is desirable therefore that the PMA for a cargo hold are provided in two different types, one inclined ladder system and the other more robust ladder system that has been proven in existing bulk carriers with a view to minimizing possibility of damages to

**SC
190**
(cont)

and consequential loss of means of access to a cargo hold at the same time due to a cargo damage during voyages and/or during cargo handling in ports. Such damages to both of the means of access to a cargo hold result in difficulty in accessing for repairs of the PMA.

Ref.

Australian AMSA Marine Orders Part 32, Appendix 17

Table 1 – Means of access for oil tankers, Resolution MSC.133(76)**1 Water ballast tanks, except those specified in the right column, and cargo oil tanks****Access to overhead structure**

1.1 For tanks of which the height is 6 m and over, permanent means of access shall be provided in accordance with .1 to .3:

Interpretation

- 1) Section 1 of Table 1 is also to be applied to void spaces in cargo area, except those spaces covered by Section 2.
- 2) Where a permanent means of access is provided adjacent to hull structure forming a wall on one side, guard rails are to be fitted on the open side of the permanent means of access (ref. to the degree of slope).
- 3) The vertical distance below the overhead structure is to be measured from the underside of the main deck plating to the top of the platform of the means of access at a given location.
- 4) The height of the tank is to be measured at each tank. For a tank the height of which varies at different bays item 1.1 is to be applied to such bays of a tank that have height 6 m and over.

Technical Background

Item 1) The guard rails are to be arranged such that the person on the permanent means of access is well protected on the free edge.

Item 3) If the height of the tank is increasing along the length of a ship the permanent means of access is to be provided locally where the height is above 6 m.

Ref.

Paragraph 10 of Annex to MSC/Circ.686.

Table 1 – Means of access for oil tankers, Resolution MSC.133(76)

1.1.1 continuous athwartship permanent access arranged at the transverse bulkheads and at every deck transverse, at a minimum of 1.8 m to a maximum of 2.5 m below the overhead structure. If the access is fitted on the side of the unobstructed side of the web plating, then lightening holes of at least 300 mm diameter shall be fitted in the web plating, providing access adjacent to both sides of each tripping bracket;

Interpretation

- 1) Permanent means of access for inspection specified in 1.1.1 is to be provided for transverse bulkheads of tanks on stiffened surface.
- 2) When deck stiffeners are fitted outside of the tank and bulkhead connection to deck is plate to plate with no stiffeners or brackets inside the tank, then a continuous athwartship access may not be required.
- 3) Also, continuous athwartship permanent access may not be fitted at deck transverses for an overhead structure where deck stiffeners and transverses fitted on the out side surface of deck plating of the tank.
- 4) In such a case where the depth of deck transverses is less than 1800mm for design scantling and the athwartship permanent access is to be fitted to the deck transverses the required distance of 1.8 to 2.5m below the overhead structure is provided above the permanent means of access by an extension.
- 5) Alternatively the depth of deck transverses is to be extended so that the required distance below overhead structure is provided above the extended face plate of the deck transverses.

(Operational safety measures should be detailed in an access manual.)

Technical Background

- Interpretation item 2): The PMA is intended for access to internal structures. In such a case where internal structures are entirely outside of the tank PMA becomes superfluous as long as deck plating and upper part of bulkhead plating are accessible outside of the tank.
- The longitudinal permanent means of access in the upper part of the longitudinal bulkheads allows overall inspection of deck transverses and close up surveys of their potential critical areas in the vicinity of their ends.

Table 1 – Means of access for oil tankers, Resolution MSC.133(76)

1.1.2 at least one longitudinal permanent means of access at a minimum of 1.8 m to a maximum of 2.5 m below the overhead structure. Where the longitudinal bulkhead contains attached framing, the access shall be provided at that side; and

Interpretation

- 1) Longitudinal permanent means of access is to be provided on each side of the tank if an alternative arrangement is applied in place of the continuous athwartship permanent means of access at every deck transverse.
- 2) For tanks with no internal stiffeners arranged in top of the longitudinal bulkheads on either side or in deck, no longitudinal permanent access are to be provided unless required by item 1.1.3 of Table 1. This will typically apply to product tankers with webframes on deck and corrugated longitudinal bulkhead.
- 3) In case there are vertical webs and stiffeners on longitudinal bulkheads both sides within the tank a longitudinal permanent means of access is to be provided to each side of the tank.

Technical Background

Critical areas for ESP are normally found in load bearing internals. In a tank with flush internal surfaces without load bearing internals condition of plates of the flush surfaces can be assessed from the easily accessible locations outside the tank. It is therefore considered that the permanent means of access would be of little use for the intended inspections.

However those longitudinal permanent means of access suggested above as an alternative arrangement provides sufficient overall inspection of under deck structure, deck transverses and vertical webs in way of the permanent means of access and is considered efficient for the intended purposes.

**SC
190**
(cont)**Table 1 – Means of access for oil tankers, Resolution MSC.133(76)**

1.1.3 access between the arrangements specified in .1 and .2 and from the main deck to either .1 or .2.

Interpretation

Means of access to tanks may be used for access to the permanent means of access for inspection.

Technical Background

As a matter of principle, in such a case where the means of access can be utilised for the purpose of accessing structural members for inspection there is no need of duplicated installation of the PMA.

Table 1 – Means of access for oil tankers, Resolution MSC.133(76)**Access to vertical structures**

1.3 For tanks of which the height is 6 m and over, containing internal structures, permanent means of access shall be provided to each transverse web.

Interpretation

- 1) ‘Transverse web’ includes vertical structures of non-watertight transverse bulkheads (swash bulkheads).
- 2) A combination of vertical ladders on transverse webs and alternate means as may be provided for small vessels.
- 4) Center and side struts (cross ties) are included as part of the ring web frame and PMA is to be provided for struts if they are at 6 m or more above the tank bottom to the extent necessary for visual inspection at a reasonable vicinity to toes of end brackets.
- 5) For tanks of which the height is 6 m and over, containing internal structures such as longitudinals and transverse webs, permanent means of access are to be provided to the transverse webs by means of longitudinal permanent means of access which are integrated in the structural member, which are to be in alignment with horizontal girders of transverse bulkheads.

Technical Background

- Though the types of permanent means of access to each transverse web are not specified in paragraph 1.3 of Table 1, inclined ladders or vertical ladders would meet the requirement. In large tankers inspection of all transverse webs by climbing up and down the ladders would not be an efficient way of overall and close-up. Alternative arrangement by use of longitudinal permanent means of access is preferred. They are to be provided in alignment with horizontal girders of transverse bulkheads for structural continuation and appropriate distance between them.
- Where the longitudinal permanent means of access is impracticable for smaller vessels a combination of vertical ladders on transverse webs and alternate means as may be provided.
- The longitudinal permanent means of access using wider longitudinals at an appropriate distance apart through transverse webs provide sufficient access for overall inspection and sampling and, if necessary, alternative means of access or portable means of access can be used to access the remaining part of the transverse webs. Such arrangement is considered an acceptable alternative.

**SC
190**
(cont)**Table 1 – Means of access for oil tankers, Resolution MSC.133(76)**

1.4 For tanks of which the height is less than 6 m, raft or portable means may be utilized in lieu of the permanent means of access.

Interpretation

Alternative means of access may also be used in place of raft.

Table 1 - Means of access for oil tankers, Resolution MSC.133(76)**FOREPEAK TANKS****Interpretation**

Fore peak tanks with a depth of 6 m or more at the center line of the collision bulkhead shall be provided with a suitable means of access for access to critical areas such as the deck structure, overhead structure of stringers and side shell structure.

Stringers of less than 6 m in vertical distance from the overhead structure are considered to provide suitable access in combination with portable means of access.

In case the vertical distance between deck structure and the uppermost stringer or stringers are 6 m or more alternative means of access is to be provided.

Technical Background

The unique structural configurations and feed back information from service record as well as the present requirements for coating and surveys has been taken into account for identifying the types of damages and locations for enabling risk based inspections.

Table 1 – Means of access for oil tankers, Resolution MSC.133(76)**2 Wing water ballast tanks less than 5 m width forming double side spaces and their bilge hopper sections*****Access to the overhead structure***

2.1 Where the vertical distance between horizontal upper stringer and deck head exceeds 6 m, one continuous permanent means of access shall be provided for the full length of the tank with a means to allow passing through transverse swash bulkheads installed a minimum of 1.8 m to a maximum of 2.5 m from the overhead structure with a vertical access ladder at each end and mid-span of tank.

Interpretation

- 1) Section 2 of Table 1 is also to be applied to wing tanks designed as void spaces.
- 2) For a tank the vertical distance between horizontal upper stringer and deck head of which varies at different sections item 2.1 is to be applied to such sections that falls under the criteria.
- 3) The continuous permanent means of access may be a wide longitudinal, which provides access to critical details on the opposite side by means of platforms as necessary on webframes. In case the vertical opening of the web is located in way of the open part between the wide longitudinal and the longitudinal on the opposite side, platforms shall be provided on both sides of the web to allow safe passage through the web.

Technical Background

Item 1) Reg. II-1/3-6.2.1 requires each space within the cargo area shall be provided with a permanent means of access. Though void spaces are not addressed in the technical provisions contained in Resolution MSC.133(76) it is arguable whether PMA is not required in void spaces. PMA or portable means of access are necessary arrangement to facilitate inspection of the structural condition of the space and the boundary structure. Therefore the requirements of Section 2 of Table 1 is to be applied to double hull spaces even designed as void spaces.

Item 2) The interpretation of varied tank height in item 1 of Table 1 is applied to the vertical distance between horizontal upper stringer and deck head for consistency.

Table 1 – Means of access for oil tankers, Resolution MSC.133(76)

- 2.2 For bilge hopper sections of which the vertical distance from baseline to the upper knuckle point is 6 m and over, one longitudinal permanent means of access shall be provided for the full length of the tank. It shall be accessible by vertical permanent means of access at both ends of the tank.

Interpretation

- 1) The longitudinal continuous permanent means of access may be installed at a minimum 1.6 m to a maximum 3 m from top of bilge hopper section. When extension platform is arranged on the web, allowing hands on access to critical areas in upper knuckle point of bilge section, then the requirement to vertical ladder for access to these, as given in 2.5.1, will not apply.
- 2) Alternatively the longitudinal continuous permanent means of access may be installed at a minimum of 1.2 m to a maximum of 1.8 m below the top of the clear opening of the web ring in way of the knuckle point allowing a use of portable means of access to reach identified structural critical areas.
- 3) The longitudinal continuous permanent means of access may otherwise be installed at a location within 6 m from the knuckle point if used in combination with alternative methods to gain an access to the knuckle point.
- 4) Permanent means of access between the longitudinal continuous permanent means of access and the bottom of the space is to be provided.
- 5) The height of a bilge hopper tank located outside of the parallel part of vessel is to be taken as the maximum of the clear vertical distance measured from the bottom plating to the hopper plating of the tank.
- 6) The foremost and aftmost bilge hopper ballast tanks with raised bottom, of which the height is 6 m and over, a combination of transverse and vertical PMA for access to the upper knuckle point for each transverse web is to be accepted in place of the longitudinal permanent means of access.

Technical Background

Interpretation 4): The bilge hopper tanks at fore and aft of cargo area narrow due to raised bottom plating and the actual vertical distance from the bottom of the tank to hopper plating of the tank is more appropriate to judge if a portable means of access could be utilized for the purpose.

Interpretation 5): in the foremost or aftmost bilge hopper tanks where the vertical distance is 6 m or over but installation of longitudinal permanent means of access is not practicable permanent means of access of combination of transverse and vertical ladders provides an alternative means of access to the upper knuckle point.

**SC
190
(cont)****Table 1 – Means of access for oil tankers, Resolution MSC.133(76)**

- 2.3 Where the vertical distance referred to in 2.2 is less than 6 m, portable means of access may be utilised in lieu of the permanent means of access. To facilitate the operation of the portable means of access, in-line openings in horizontal stringers should be provided. The openings should be of an adequate diameter and should have suitable protective railings.

Interpretation

N/A

Table 1 – Means of access for oil tankers, Resolution MSC.133(76)

- 2.4 Whenever practicable, the distance between the overhead structure and the uppermost longitudinal stringer and between the longitudinal stringers should not exceed 6 m.

Interpretation

1) Longitudinal permanent means of access installed in accordance with paragraph 2.1 in the upper most space and at a vertical distance not exceeding 6 m within the remaining part of the double side spaces provide access to the overhead structure as well as to the vertical structure. Plated stringers are to be provided in alignment with horizontal girders of transverse bulkheads for structural continuity. The maximum distance between the deck head and the uppermost plated stringer and between the longitudinal plated stringers in any case is not to exceed 9 m.

Stringer in the context of Section 2 of Table 1 is taken to be a horizontal structure that is extended from side shell plating to a longitudinal bulkhead and provides passage of clear width of 600 mm or more. It may be a plating construction with stiffeners or a build up construction with wide longitudinals, which serves as longitudinal permanent means of access.

Technical Background

- 1) The functional purposes of the permanent means of access are to enable to monitor the condition of the ship and to facilitate close-up inspections and thickness measurements of the ship's structure. The plating stringers or the build-up stringers installed not exceeding 6m apart vertically provide access to underdeck structures and overhead and vertical structures above the permanent means of access, thus satisfy the technical provision of items 2.1, 2.4 and 2.5 of Table 1.

Table 1 – Means of access for oil tankers, Resolution MSC.133(76)***Access to the vertical structure***

2.5 Vertical permanent means of access shall be provided to each transverse web in the following cases where the vertical distance is 6 m and over:

- .1 from baseline to the upper knuckle point of the bilge hopper section;
- .2 from the upper knuckle point of the bilge hopper section to main deck where no horizontal stringers are provided; and
- .3 between horizontal stringers.

Interpretation

- 1) **PMA for inspection of the vertical structure:** (See the interpretation of stringers item 2.4 of Table 1)
- 2) Means for facilitating a use of a portable means of access for inspection of the upper part of transverse web is to be provided, where the vertical distance defined in paragraph 2.5 is less than 6 m and vertical PMA is not provided.
- 3) Vertical ladders that are fitted on vertical structures for inspection should comprise one or more ladder linking platforms spaced not more than 6 m apart vertically and displace to one side of the ladder. Adjacent sections of ladder should be laterally offset from each other by at least the width of the ladder. (Paragraph 20 of MSC/Circ.686) (Extract from the interpretation of TP.5)
- 4) Continuous longitudinal permanent means of access as required for deck area in 2.1 is acceptable as alternative to vertical means of access on every vertical web when distance between the longitudinal continuous permanent means is not exceeding 6 m.
- 5) The continuous longitudinal permanent means of access are to provide access to critical details on the opposite side by means of platforms fitted on web frames as necessary. In case the vertical opening of the web is located in way of the open part between the longitudinal permanent means of access and a longitudinal on the other side of the space, platforms are to be provided on both sides of the web to allow safe passage through the web.
- 6) The height of a bilge hopper tank located outside of the parallel part of vessel is to be taken as the maximum of the clear vertical height measured from the bottom plating to the hopper plating of the tank.

Technical Background

- 1) As provided in the interpretation for paragraph 2.4 of Table 1, the longitudinal permanent means of access described therein facilitate access from the stringers to critical areas of vertical structure, i.e. transverse web and joining parts of longitudinals. Portable means of access is to be used for the higher area between the adjacent longitudinal permanent means of access which are spaced not exceeding 6m apart.
- 2) The interpretation of paragraph 2.5 above is in the same vein of the alternative means of access for paragraph 1.3 of Table 1, i.e. the horizontal permanent means of access in place of inclined or vertical ladders to transverse webs.

**SC
190
(cont)****Table 1 – Means of access for oil tankers, Resolution MSC.133(76)**

2.6 Access holes within 600 mm of the stringer shall be provided in each transverse web/swash bulkhead above each stringer and tank base.

Interpretation

If the vertical opening is at a height of more than 600 mm steps and handgrips are to be provided. In all cases it should be demonstrated that an injured person can be easily evacuated.

Technical Background

SOLAS Reg. II-1/3-6.5.2 allows vertical openings higher than 600 mm from the bottom shell plating if gratings or other foot holds are provided. The above interpretation aimed at a consistency with the Regulation.

**SC
190
(cont)****Table 1 – Means of access for oil tankers, Resolution MSC.133(76)**

2.7 In the case where the vertical distance referred to in 2.5 is less than 6 m, portable means may be utilised in lieu of the permanent means of access.

Interpretation

The interpretation of paragraph 2.2 of Table 1 refers.

**SC
190
(cont)**

Table 2 – Means of access for bulk carriers, Resolution MSC.133(76)

Arrangement of means of access for single side skin bulk carriers as written in the Technical Provisions.

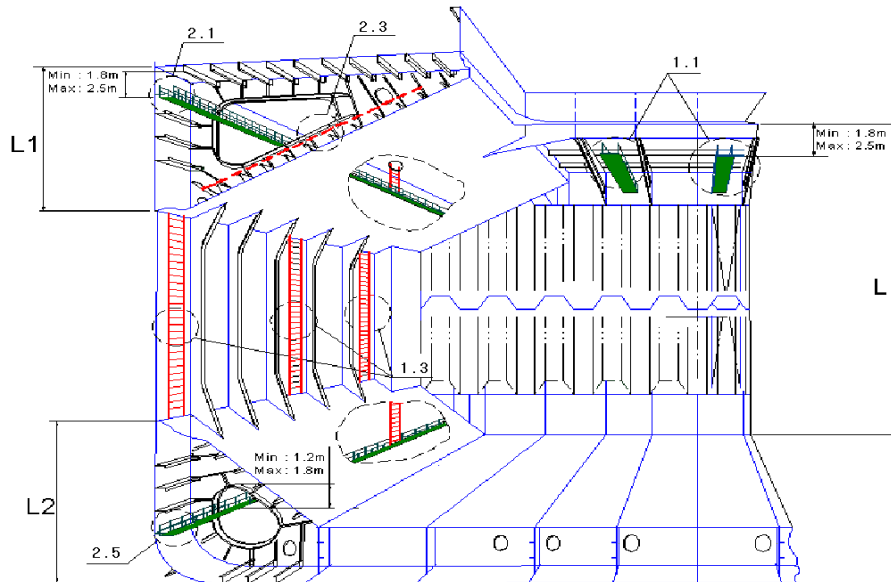

**SC
190**
(cont)**Table 2 – Means of access for bulk carriers, Resolution MSC.133(76)****1 Cargo holds****Access to overhead structure**

1.1 At least 3 permanent means of access shall be fitted to provide access to the overhead structure at both sides of the cross deck and in the vicinity of the centreline. Each means of access shall be accessible from the cargo hold access or directly from the main deck and installed at a minimum of 1.8 m to a maximum of 2.5 m below the deck.

Interpretation

- 1) Interconnected means of access under the cross deck for access to three locations at both sides and in the vicinity of the centerline is acceptable as the three means of access.
- 2) Permanent means of access fitted at three separate locations accessible independently, one at each side and one in the vicinity of the centerline is acceptable.
- 3) Athwartship permanent means of access fitted on transverse bulkheads from side to side at a minimum 1.6 m to a maximum 3 m below the deck head is considered as an alternative to the requirement.
- 4) Access to the means of access to overhead structure of cross deck may be via the upper stool.
- 5) Attention is to be paid to the structural strength where any access opening is provided in the main deck or cross deck.
- 6) The requirements for bulk carrier cross deck structure is also considered applicable for ore carriers.

Technical Background

Pragmatic arrangements of the PMA are provided.

**SC
190
(cont)****Table 2 – Means of access for bulk carriers, Resolution MSC.133(76)**

1.2 Alternatively, movable means of access may be utilized for access to the overhead structure of cross deck if its vertical distance is 17 m or less above the tank top.

Interpretation

- 1) The movable means of access to the underdeck structure of cross deck need not necessarily be carried on board the vessel. It is sufficient if it is made available when needed.

- 2) The requirements for bulk carrier cross deck structure is also considered applicable for ore carriers.

Table 2 – Means of access for bulk carriers, Resolution MSC.133(76)***Access to vertical structures***

1.3 Permanent means of vertical access shall be provided in all cargo holds and built into the structure to allow for an inspection of a minimum of 25 % of the total number of hold frames port and starboard equally distributed throughout the hold including at each end in way of transverse bulkheads. But in no circumstance shall this arrangement be less than 3 permanent means of vertical access fitted to each side (fore and aft ends of hold and mid-span). Means to readily secure safety cages to the permanent means of access shall be provided. Permanent means of vertical access fitted between two adjacent hold frames is counted for an access for the inspection of both hold frames. A means of portable access may be used to gain access over the sloping plating of lower hopper ballast tanks.

Interpretation

- 1) For practical reasons a single vertical ladder (not staggered ones) is accepted for the inspection of the hold side frames in a single side skin construction.
- 2) The minimum width of vertical ladders for access to hold frames is to be 350 mm measured between stringers and the maximum pitch of the treads is to be 350 mm..
- 3) For double side skin bulk carrier no vertical ladders for inspection of the cargo hold surfaces are to be provided. Inspection of this structure is to be provided from within the double hull space.
- 4) Safety cage in the context of item 1.3 of Table 1 is such that is to be arranged to protect surveyor/crews from falling form the ladder and provides rest during inspection. For example a safety harness worn by the personnel during the inspection is an acceptable equivalence. If safety harness is to be used, means should be provided for connecting the safety harness in suitable places in a practical way.

Technical Background

Item 4) Permanent installation of a safety cage is not practicable due to high risks of cargo damages. Portable one for use by individuals is to be envisioned. Alternatively safety harness may be used.

The maximum pitch of the treads of 350 mm is applied with a view to reducing trapping cargoes.

**SC
190
(cont)****Table 2 – Means of access for bulk carriers, Resolution MSC.133(76)**

1.4 In addition, portable or movable means of access shall be utilized for access to the remaining hold frames up to their upper brackets and transverse bulkheads.

Interpretation

Portable, movable or alternative means of access also is to be applied to corrugated bulkheads.

**SC
190**
(cont)

Table 2 – Means of access for bulk carriers, Resolution MSC.133(76)

2 Ballast tanks

Interpretation

Refer to the Observation for paragraph 2.1 of Reg. II-1/3-6.

**SC
190
(cont)****Table 2 – Means of access for bulk carriers, Resolution MSC.133(76)****Top side tanks**

2.1 For each topside tank of which the height is 6 m and over, one longitudinal continuous permanent means of access shall be provided along the side shell webs and installed at a minimum of 1.8 m to a maximum of 2.5 m below deck with a vertical access ladder in the vicinity of each access to that tank.

Interpretation

One continuous longitudinal permanent means of access may be provided along the side shell webs and installed at a minimum of 1.6 m to a maximum of 3 m below deck with a vertical access ladder in the vicinity of each access to that tank.

Technical Background

Structural configuration may require flexibility of the location of longitudinal continuous permanent means of access.

**SC
190
(cont)****Table 2 – Means of access for bulk carriers, Resolution MSC.133(76)**

2.2 If no access holes are provided through the transverse ring webs within 600 mm of the tank base and the web frame rings have a web height greater than 1 m in way of side shell and sloping plating, then step rungs/grab rails shall be provided to allow safe access over each transverse web frame ring.

Interpretation

N/A

**SC
190
(cont)****Table 2 – Means of access for bulk carriers, Resolution MSC.133(76)**

2.3 Three permanent means of access, fitted at the end bay and middle bay of each tank, shall be provided spanning from tank base up to the intersection of the sloping plate with the hatch side girder. The existing longitudinal structure may be used as part of this means of access.

Interpretation

If the longitudinal structures on the sloping plate are fitted outside of the tank a means of access is to be provided.

**SC
190
(cont)****Table 2 – Means of access for bulk carriers, Resolution MSC.133(76)**

2.4 For topside tanks of which the height is less than 6 m, a portable means may be utilized in lieu of the permanent means of access.

Interpretation

N/A

Table 2 – Means of access for bulk carriers, Resolution MSC.133(76)***Bilge hopper tanks***

2.5 For each bilge hopper tank of which the height is 6 m and over, one longitudinal continuous permanent means of access shall be provided along the side shell webs and installed at a minimum of 1.2 m to a maximum of 1.8 m below the top of the clear opening of the web ring with a vertical access ladder in the vicinity of each access to the tank.

Interpretation

- 1) Permanent means of access between the longitudinal continuous permanent means of access and the bottom of the space is to be provided.
- 2) The longitudinal continuous permanent means of access may be alternatively located through the upper web plating above the clear opening of the web ring, when this arrangement facilitates more suitable inspection of identified structurally critical areas. A wide longitudinal frame of at least 600 mm clear width may be used for the purpose of the longitudinal continuous permanent means of access.
- 3) The height of a bilge hopper tank located outside of the parallel part of vessel is to be taken as the maximum of the clear vertical height measured from the bottom plating to the hopper plating of the tank.
- 4) It should be demonstrated that portable means for inspection can be deployed and made readily available in the areas where needed.
- 5) For double side skin bulk carriers the longitudinal continuous permanent means of access may be installed at a location within 6 m from the knuckle point if used in combination with alternative methods to gain an access to the knuckle point.

Technical Background

The functional requirement to get access to the identified critical area can be satisfied by the alternative arrangement given in item 5).

**SC
190
(cont)****Table 2 – Means of access for bulk carriers, Resolution MSC.133(76)**

2.6 If no access holes are provided through the transverse ring webs within 600 mm of the tank base and the web frame rings have a web height greater than 1 m in way of side shell and sloping plating, then step rungs/grab rails shall be provided to allow safe access over each transverse web frame ring.

Interpretation

N/A

**SC
190
(cont)****Table 2 – Means of access for bulk carriers, Resolution MSC.133(76)**

2.7 For bilge hopper tanks of which the height is less than 6 m, a portable means may be utilized in lieu of the permanent means of access.

Interpretation

- 1) The interpretation of paragraph 2.7 of Table 1 refers.
- 2) It should be demonstrated that a portable means can be deployed and made readily available for inspection in the areas where needed.

**SC
190**
(cont)

Table 2 – Means of access for bulk carriers, Resolution MSC.133(76)

Double side skin tanks

2.8 Permanent means of access shall be provided in accordance with the applicable sections of table 1.

Interpretation

N/A

Table 2 - Means of access for bulk carriers, Resolution MSC.133(76)**FOREPEAK TANKS****Interpretation**

Fore peak tanks with a depth of 6 m or more at the center line of the collision bulkhead shall be provided with a suitable means of access for access to critical areas such as the deck structure, overhead structure of stringers and side shell structure.

Stringers of less than 6 m in vertical distance from the overhead structure are considered to provide suitable access in combination with portable means of access.

In case the vertical distance between deck structure and the uppermost stringer or stringers are 6 m or more alternative means of access is to be provided.

Technical Background

The unique structural configurations and feed back information from service record as well as the present requirements for coating and surveys has been taken into account for identifying the types of damages and locations for enabling risk based inspections.

Table 2 – Means of access for bulk carriers, Resolution MSC.133(76)***Footnote***

For ore carriers, permanent means of access in wing ballast tanks shall be provided in accordance with the applicable section of table 1.

Interpretation

The requirements to Ore Carrier wing tanks arranged as void spaces should be as for wing ballast tanks.

Technical Background

The wing tanks are prone to damages even when arranged as void space, rafting is not an option and permanent means of access are needed to monitor the structural condition.

End of Document
