



Ref. T4/4.01

MSC.1/Circ.1312  
10 June 2009

**REVISED GUIDELINES FOR THE PERFORMANCE AND TESTING CRITERIA,  
AND SURVEYS OF FOAM CONCENTRATES FOR  
FIXED FIRE-EXTINGUISHING SYSTEMS**

- 1 The Maritime Safety Committee, at its sixtieth session (6 to 10 April 1992), approved Guidelines for the performance and testing criteria, and surveys of low-expansion foam concentrates for fixed fire-extinguishing systems (MSC/Circ.582).
- 2 The Committee, at its sixty-eighth session (28 May to 6 June 1997), approved Guidelines for the performance and testing criteria, and surveys of expansion foam concentrates for fixed fire-extinguishing systems of chemical tankers (MSC/Circ.799).
- 3 The Sub-Committee on Fire Protection, at its fifty-third session (16 to 20 February 2009) reviewed the aforementioned Guidelines and made amendments to the test methods for both types of foam concentrates which combined the test procedure into one document.
- 4 The Committee, at its eighty-sixth session (27 May to 5 June 2009), after having considered the above proposal by the Sub-Committee on Fire Protection, at its fifty-third session, approved the Revised Guidelines for the performance and testing criteria, and surveys of foam concentrates for fixed fire-extinguishing systems, as set out in the annex.
- 5 Member Governments are invited to apply the annexed Guidelines when approving foam concentrates for fixed fire-extinguishing systems onboard tankers and chemical tankers and bring them to the attention of ship designers, shipowners, equipment manufacturers, test laboratories and other parties concerned.
- 6 This circular supersedes MSC/Circ.582 and Corr.1, and MSC/Circ.799. Type approvals conducted in accordance with the aforementioned Guidelines should remain valid until 1 July 2012.

\*\*\*



## ANNEX

**REVISED GUIDELINES FOR THE PERFORMANCE AND TESTING CRITERIA,  
AND SURVEYS OF FOAM CONCENTRATES FOR  
FIXED FIRE-EXTINGUISHING SYSTEMS****1 GENERAL****1.1 Application**

These Guidelines apply to the foam concentrates used for fixed deck foam fire-extinguishing systems required for tankers by SOLAS regulations II-2/10.8 and chapter 14 of the International Code for Fire Safety Systems (FSS Code), and chemical tankers as specified by SOLAS regulation II-2/1.6.2.1.2 and the International Code for the Construction and Equipment of Ships Carrying Dangerous Chemicals in Bulk (IBC Code). These Guidelines also apply to foam concentrates for fixed foam fire-extinguishing systems in machinery spaces according to chapter 6 of the FSS Code and to portable foam applicators according to chapter 4 of the FSS Code. These Guidelines do not apply to the foam generating equipment, only the foam concentrate.

**1.2 Definitions**

For the purpose of these Guidelines, the following definitions apply:

1.2.1 *Foam (fire fighting)* is an aggregate of air filled bubbles formed from an aqueous solution of suitable foam concentrate.

1.2.2 *Foam solution* is a solution of foam concentrate and water.

1.2.3 *Foam concentrate* is a liquid which, when mixed with water in the appropriate concentration, gives a foam solution.

1.2.4 *Expansion ratio* is the ratio of the volume of foam to the volume of foam solution from which it was made.

1.2.5 *Spreading coefficient* is a measurement of the ability of one liquid to spontaneously spread across another.

1.2.6 *25% (50%) drainage time* is the time for 25% (50%) of the liquid content of a foam to drain out.

1.2.7 *Gentle application* is the application of foam to the surface of a liquid fuel via a backboard, tank wall or surface.

1.2.8 *Sediment* is insoluble particles in the foam concentrate.

1.2.9 *Aqueous film-forming foam concentrate (AFF)* is a foam concentrate based on a mixture of hydrocarbon and fluorinated surface active agents.

1.2.10 *Alcohol-resistant foam concentrate (AR)* is a foam concentrate that is resistant to breakdown when applied to the surface of alcohol or other polar solvents.

1.2.11 *Film-forming fluoroprotein foam concentrate (FFFP)* is a foam concentrate which has the ability to form an aqueous film on the surface of some hydrocarbons.

1.2.12 *Fluoroprotein foam concentrate (FP)* is a protein foam concentrate with added fluorinated surface active agents.

1.2.13 *Protein foam concentrate (P)* is a foam concentrate made from hydrolyzed protein materials.

1.2.14 *Synthetic foam concentrate (S)* is a foam concentrate based on a mixture of hydrocarbon surface active agents and which may contain fluorocarbons with additional stabilizers.

1.2.15 *Type A foam concentrates* are alcohol-resistant or multi-purpose foam concentrates.

1.2.16 *Type B foam concentrates* are all regular type foam concentrates that are not alcohol-resistant, including fluoroprotein and aqueous film-forming (AFF) foam concentrates.

## **2 SAMPLING PROCEDURE**

The sampling method should ensure representative samples which should be stored in filled containers.

The sample size should be:

- .1 2 x 20 l containers (or other standard shipping containers) for type tests (see section 3); and
- .2 2 l for periodical controls (see section 4).

## **3 TESTS FOR TYPE APPROVAL OF FOAM CONCENTRATES**

For foam concentrate type approval, the tests under paragraphs 3.1 to 3.14 below should be performed by the foam concentrate manufacturer at laboratories acceptable to the Administration.

### **3.1 Freezing and thawing**

3.1.1 Before and after temperature conditioning in accordance with paragraph 3.1.2 below, the foam concentrate should show no visual sign of stratification, non-homogeneity or sedimentation.

3.1.2 Freezing and thawing test:

- .1 apparatus:
  - .1 freezing chamber, capable of achieving temperatures required, as stated in paragraph 3.1.2.2.1 below;
  - .2 polyethylene tube, approximately 10 mm diameter, 400 mm long and sealed and weighted at one end, with suitable spacers attached. Figure 1 shows a typical form; and
  - .3 500 ml cylinder, approximately 400 mm high and 65 mm in diameter.

- .2 procedure:
  - .1 set the temperature of the freezing chamber to a temperature which is 10°C below the freezing point of the sample measured in accordance with standard BS 5117, section 1.3 (excluding 5.2 in the standard). To prevent the glass measuring cylinder from breaking, due to expansion of the foam concentrate on freezing, insert the tube into the measuring cylinder, sealed end downward, weighted if necessary to avoid flotation, and the spacers ensuring it remains approximately on the central axis of the cylinder. Place the cylinder with the sample in the chest, cool it and maintain at the required temperature for 24 h. At the end of this period, thaw the sample for not less than 24 h and not more than 96 h in an ambient temperature of 20 to 25°C;
  - .2 repeat the procedure described in the above subparagraph three times to give four cycles of freezing and thawing; and
  - .3 condition the sample for seven days at 60°C followed by one day at room temperature. The sample shall then be examined for visual signs of stratification, non-homogeneity or sedimentation.

### 3.2 Heat stability

An unopened 20 l container (or other standard shipping container), as supplied by the manufacturer from a production batch, should be maintained for seven days at 60°C, followed by one day at room temperature. Following this conditioning, the foam liquid after agitating/stirring will be subjected to the fire test as per subsection 3.9. Only fire tests as per subsection 3.9 should be performed with the heat conditioned sample.

### 3.3 Sedimentation

3.3.1 Any sediment in the concentrate prepared in accordance with section 2 should be dispersible through a 180 µm sieve, and the percentage volume of sediment should not be more than 0.25% when tested in accordance with paragraph 3.3.2 below.

3.3.2 The test should be carried out as follows:

- .1 apparatus:
  - .1 graduated centrifuge tubes;
  - .2 centrifuge operating at  $6,000 \pm 100$  m/s<sup>2</sup>;
  - .3 180 µm sieve complying with standard ISO 3310-1; and
  - .4 plastic wash bottle.

**Note:** a centrifuge and tubes complying with standard ISO 3734 are suitable; and

- .2 procedure: centrifuge each sample for 10 min. Determine the volume of the sediment and determine the percentage of this volume with respect to the centrifuged sample volume. Wash the contents of the centrifuge tube onto the sieve and check that the sediment can or cannot be dispersed through the sieve by the jet from the plastic wash bottle.

**Note:** It is possible that the test method is not suitable for some non-Newtonian foam concentrates. In this case an alternative method, to the satisfaction of the Administration, should be used so that compliance with this requirement can be verified.

### 3.4 Kinematic viscosity

3.4.1 The test should be carried out according to standard ASTM D 445-86 or ISO 3104. Kinematic viscosity should not exceed 200 mm<sup>2</sup>/s.

3.4.2 The method for determining viscosity of non-Newtonian foam concentrates or kinematic viscosity exceeding 200 mm<sup>2</sup>/s should be to the satisfaction of the Administration. A suitable method is described in standard EN 1568.

### 3.5 pH value

The pH of the foam concentrate prepared in accordance with section 2 should be not less than 6 and not more than 9.5 at 20 ± 2°C.

### 3.6 Film formation of the foam solution (if applicable)

3.6.1 The spreading coefficient should be determined using the following formula:

$$S = T_c - T_s - T_i$$

where:

$S$  is the spreading coefficient;

$T_c$  is the surface tension of cyclohexane (N/m);

$T_s$  is the surface tension of the foam solution (N/m);

$T_i$  is the interfacial tension between the foam solution and cyclohexane (N/m).

$T_c$ ,  $T_s$  and  $T_i$  should be determined according to paragraph 3.6.2 below.

The spreading coefficient  $S$  should be greater than 0.

#### 3.6.2 Determination of $T_c$ , $T_s$ and $T_i$

.1 materials:

- .1 solution of foam concentrate, at the recommended usage concentration in distilled water complying with standard ISO 3696; and

**Note:** The solution may be made up in a 100 ml volumetric flask using a pipette to measure the foam concentrate.

- .2 for  $T_c$  and  $T_i$ , cyclohexane of purity not less than 99%;
- .2 procedures for surface tension: determine  $T_s$  at a temperature of  $20 \pm 2^\circ\text{C}$  using the ring or plate method of standard ISO 304; and
- .3 procedure for interfacial tension: after measuring the surface tension in accordance with subparagraph .2 above, introduce a layer of cyclohexane at  $20 \pm 2^\circ\text{C}$  onto the foam solution, being careful to avoid contact between the ring or plate and the cyclohexane. Wait  $6 \pm 1$  min and measure  $T_i$ .

### 3.7 Expansion ratio

3.7.1 The test should be carried out according to paragraph 3.7.2 with simulated seawater at about  $20^\circ\text{C}$  having the characteristics stated in paragraph 3.7.3.

#### 3.7.2 Determination of the expansion ratio

- .1 apparatus:
  - .1 plastic collecting vessel of volume  $V$ , known to  $\pm 16$  ml, as shown in figure 2, equipped with a bottom discharge facility;
  - .2 foam collector, as shown in figure 3; and
  - .3 foam making equipment with nozzle, as shown in figure 4, which when tested with water has a flow rate of 11.4 l/min at a nozzle pressure of  $6.3 \pm 0.3$  bar;
- .2 procedure:
  - .1 check that the pipe work and hose from the foam solution tank to the nozzle is completely full of solution. Set up the nozzle horizontally directly in front of the foam collector with the front of the nozzle  $3 \pm 0.3$  m from the top edge of the collector. Wet the vessel internally and weigh it ( $W_1$ ). Set up the foam equipment and adjust the nozzle pressure to give a flow rate of 11.4 l/min. Discharge the foam and adjust the height of the nozzle so that the discharge strikes the collector centrally. Keep the nozzle horizontal. Stop the foam discharge and rinse all foam from the collector. Check that the foam solution tank is full. Start discharging the foam and after  $30 \pm 5$  s to allow the discharge to stabilize, place the collecting vessel, with the discharge outlet closed, on the collector. As soon as the vessel is full, remove it from the collector, strike the foam surface level with the rim and start the clock. Weigh the vessel ( $W_2$ );
  - .2 calculate the expansion  $E$  from the equation:

$$E = \frac{V}{W_2 - W_1}$$

in which it is assumed that the density of the foam solution is 1 and where:

$V$  is the vessel volume in m<sup>3</sup>;

$W_1$  is the mass of the empty vessel in grams;

$W_2$  is the mass of the full vessel in grams; and

- .3 open the drainage facility and collect the foam solution in the measuring cylinder to measure the 25% drainage time (see paragraph 3.8.1 below).

3.7.3 Simulated sea water may be made up by dissolving in 0.9584 kg of potable water:

25 g	Sodium chloride	(NaCl);
11 g	Magnesium chloride	(MgCl <sub>2</sub> · 6 H <sub>2</sub> O);
1.6 g	Calcium chloride	(CaCl <sub>2</sub> · 2H <sub>2</sub> O);
4 g	Sodium sulphate	(Na <sub>2</sub> SO <sub>4</sub> ).

### 3.8 Drainage time

3.8.1 The drainage time should be determined according to paragraph 3.7.2.3 above, after having determined the expansion ratio.

3.8.2 The test should be carried out with simulated seawater at about 20°C having the characteristics stated in paragraph 3.7.3 above.

### 3.9 Fire tests

Fire tests should be carried out according to paragraphs 3.9.1 to 3.9.7.

**Note:** The fire tests of this subsection 3.9 are more expensive and time consuming than the other tests of these Guidelines. It is recommended that fire tests should be carried out at the end of the test programme, so as to avoid the expense of unnecessary testing of foam concentrates which do not comply in other respects.

3.9.1 *Environmental conditions:*

- .1 air temperature  $15 \pm 5^\circ\text{C}$ ;
- .2 fuel temperature  $17.5 \pm 2.5^\circ\text{C}$ ;
- .3 water temperature  $17.5 \pm 2.5^\circ\text{C}$ ;
- .4 foam solution temperature  $17.5 \pm 2.5^\circ\text{C}$ ; and
- .5 maximum wind speed 3 m/s in proximity of the fire tray.

**Note:** If necessary, some form of wind-screen may be used.



### 3.9.2 *Observations during the fire test:*

During the fire test, record the following:

- .1 indoor or outdoor test;
- .2 air temperature;
- .3 fuel temperature;
- .4 water temperature;
- .5 foam solution temperature;
- .6 wind speed;
- .7 extinction time; and
- .8 25% burnback time.

**Note:** Burnback time may either be determined visually by an experienced person or may be determined from thermal radiation measurements (a suitable method is described in standard EN 1568).

### 3.9.3 *Foam solution:*

- .1 prepare a foam solution following the recommendations from the supplier for concentration, maximum premix time, compatibility with the test equipment, avoiding contamination by other types of foam, etc; and
- .2 the test should be carried out with simulated sea water at about 20°C having the characteristics stated in paragraph 3.7.3 above.

### 3.9.4 *Apparatus:*

- .1 fire tray: square tray with the following dimensions:

area	4.5 m <sup>2</sup> ;
depth	200 mm;
thickness of steel wall	2.5 mm;
with a vertical steel backboard 1 ± 0.05 m high and 1 ± 0.05 m long;	
- .2 foam making equipment: in accordance with paragraph 3.7.2.1 for type B foam concentrates. For type A foam concentrates, the foam application rate should be as determined by the manufacturer, up to a total of three nozzles in accordance with paragraph 3.7.2.1;

.3 burnback pot: circular burnback pot with the following dimensions:

diameter	300 ± 5 mm;
height	150 ± 5 mm;
thickness of steel wall	2.5 mm.

### 3.9.5 Fuel

3.9.5.1 For type B foams, use an aliphatic hydrocarbon mixture with physical properties according to the following specification:

distillation range	84°C to 105°C;
maximum difference between initial and final boiling points	10°C;
maximum aromatic content	1%;
density at 15°C	707.5 ± 2.5 kg/m <sup>3</sup> ;
temperature	about 20°C.

**Note:** Typical fuels meeting this specification are n-heptane and certain solvent fractions sometimes referred to as commercial heptane.

The Administration may require additional fire tests using an additional test fuel.

3.9.5.2 For type A foams, acetone and isopropyl alcohol should be used as the standard test fuels. However, the Administration may require additional fire tests using different test fuels for water-miscible cargoes that require a higher foam application rate than acetone. Impurities for all type A fuels should not exceed 1%.

### 3.9.6 Test procedure:

- .1 place the tray directly on the ground and ensure that it is level. If using heptane, add approximately 90 l of simulated sea water having the characteristics stated in paragraph 3.7.3, and check that the base of the tray is completely covered. Set up the foam nozzle horizontally, about 1 m above the ground in a position where the central part of the foam discharge will strike the centre axis of the backboard, 0.35 ± 0.1 m above the rim of the tray (gentle application). Add 144 ± 5 l of fuel, to give a nominal freeboard of 150 mm. If using acetone or isopropyl alcohol, add 234 ± 5 l of fuel directly into the tray, without water, to give a nominal freeboard of 150 mm;
- .2 ignite the tray not more than 5 min after adding the fuel and allow it to burn for a period of 60 ± 5 s after full involvement of the surface of the fuel, then start foam application; and

- .3 apply foam for  $300 \pm 2$  s. Stop foam application and after a further  $300 \pm 10$  s place the burnback pot, containing  $2 \pm 0.1$  l of fuel in the centre of the tray and ignite. Visually estimate when 25% of the tray is covered by sustained flames or by “flare up” flames (see Note below), ignoring any faint, barely visible, or transient flames.

**Note:** During the burnback test, a “flare up” may occur, in which large flames may be sustained for periods typically from 30 s to 3 min before decreasing in intensity.

#### 3.9.7 *Permissible limits:*

- .1 extinction time: not more than 5 min; and
- .2 burnback time: not less than 15 min for 25% of the surface.

### **3.10 Corrosiveness**

The storage container should be compatible with its foam concentrate throughout the service life of the foam such that the chemical and physical properties of the foam should not deteriorate below the initial values accepted by the Administration.

### **3.11 Volumic mass**

According to standard ASTM D 1298-85.

### **3.12 Batch certificate**

The foam concentrate should be delivered with a declaration of the main characteristics (sedimentation, pH value, expansion ratio, drainage time and volumetric mass). The declaration should be issued by the maker and will be the basis for the annual condition test.

### **3.13 Foam concentrate container marking**

Each foam concentrate container should be marked with complete information needed to identify the liquid and confirm its intended use. As a minimum, the following information should be included:

- .1 name and address of manufacturer;
- .2 product designation;
- .3 type of foam (synthetic, protein-based, etc.);
- .4 intended use (regular or alcohol-resistant);
- .5 batch number and reference to batch certificate;
- .6 date of manufacture;
- .7 expiry date;

- .8 reference to test standard and approvals;
- .9 recommended usage concentration;
- .10 indication if seawater compatible;
- .11 maximum and minimum storage temperature;
- .12 required onboard storage tank materials (steel, stainless steel, FRP, etc.);
- .13 quantity of foam concentrate;
- .14 indication of film forming capability; and
- .15 safety, health and environmental information.

### **3.14 Reference test and annual periodic re-test for protein-based alcohol-resistant foam concentrates**

Protein-based alcohol-resistant foam concentrates should be required to demonstrate manufacturing consistency through an annual small-scale test at a recognized test laboratory. The reference test should be performed at the same time and at the same recognized laboratory as the full-scale test defined in subsection 3.9.

The concentrate should be tested according to standards ISO 7203-3 Annex C, EN 1568-4 Annex I, SP Method 2580 or another standard acceptable to the Administration. The reference test and annual test should be carried out to the same standard.

The concentrate is deemed to fail the test if the results from the annual small scale test indicate significant changes in the foam quality compared to the reference test.

## **4 PERIODICAL CONTROLS OF FOAM CONCENTRATES STORED ON BOARD**

The attention of the Administration is drawn to the fact that particular installation conditions (excessive ambient storage temperature, contamination of the foam concentrate, incomplete filling of the tank, etc.) may lead to an abnormal ageing of the concentrates.

For periodical control of foam concentrates, the tests under paragraphs 4.1 to 4.7 should be performed by the shipowner or operator. They should be carried out at laboratories or authorized service suppliers acceptable to the Administration.

The deviations in the values obtained by these tests, in respect of those obtained during the type approval tests, should be within the ranges acceptable to the Administration.

Tests under paragraphs 4.1, 4.3 and 4.4 should be carried out on samples maintained at 60°C for 24 h and subsequently cooled to the test temperature.

### **4.1 Sedimentation**

According to paragraph 3.3 above.

#### **4.2 pH value**

According to paragraph 3.5 above.

#### **4.3 Expansion ratio**

According to paragraph 3.7 above.

#### **4.4 Drainage time**

According to paragraph 3.8 above.

#### **4.5 Volumic mass**

According to paragraph 3.11 above.

#### **4.6 Small scale fire test for protein-based alcohol-resistant foam concentrates**

According to paragraph 3.14 above.

#### **4.7 Chemical stability test for protein-based alcohol-resistant foam concentrates**

Protein-based alcohol-resistant foam concentrates should be subjected to a stability test with acetone. A foam solution should be prepared at the approved concentration and gently applied to the surface of a tray containing acetone. The concentrate is deemed to fail the test if the foam solution mixes with the acetone.

### **5 INTERVALS OF PERIODIC CONTROLS**

Except for tests in accordance with paragraph 4.7 the first periodical control of foam concentrates should be performed not more than 3 years after being supplied to the ship, and after that, every year. The tests required by paragraph 4.7 should be performed prior to delivery to the ship and annually thereafter.

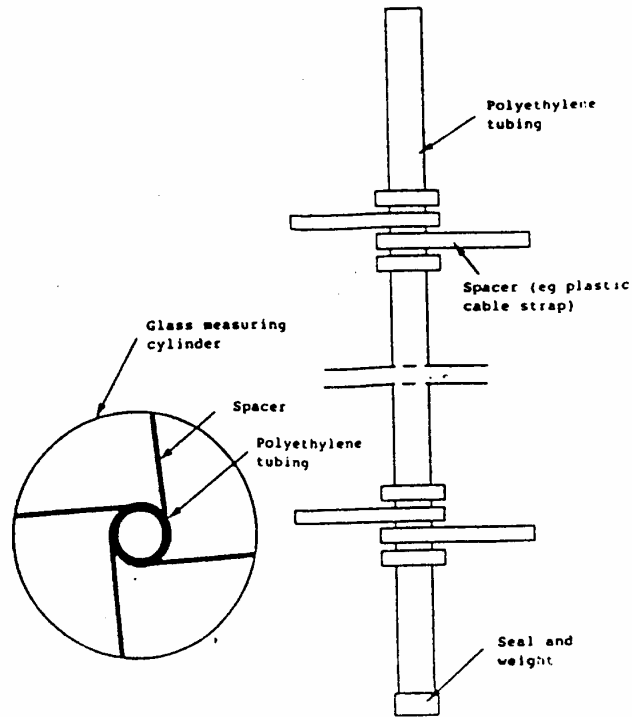

Figure 1 – Typical form of polyethylene tube

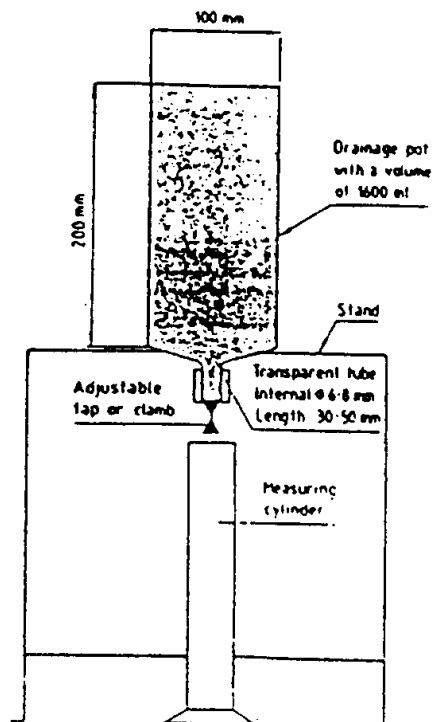

Figure 2 – Collecting vessel for determination of expansion and drainage time

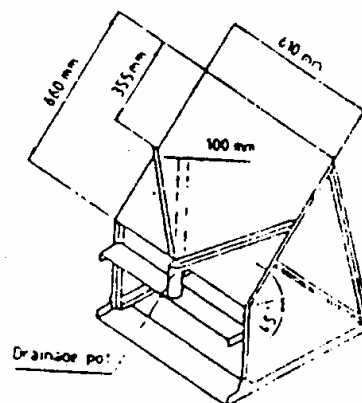

Figure 3 – Foam collector for expansion and drainage measurement

Note: Suitable materials for the collection surface are stainless steel, aluminium, brass or plastics

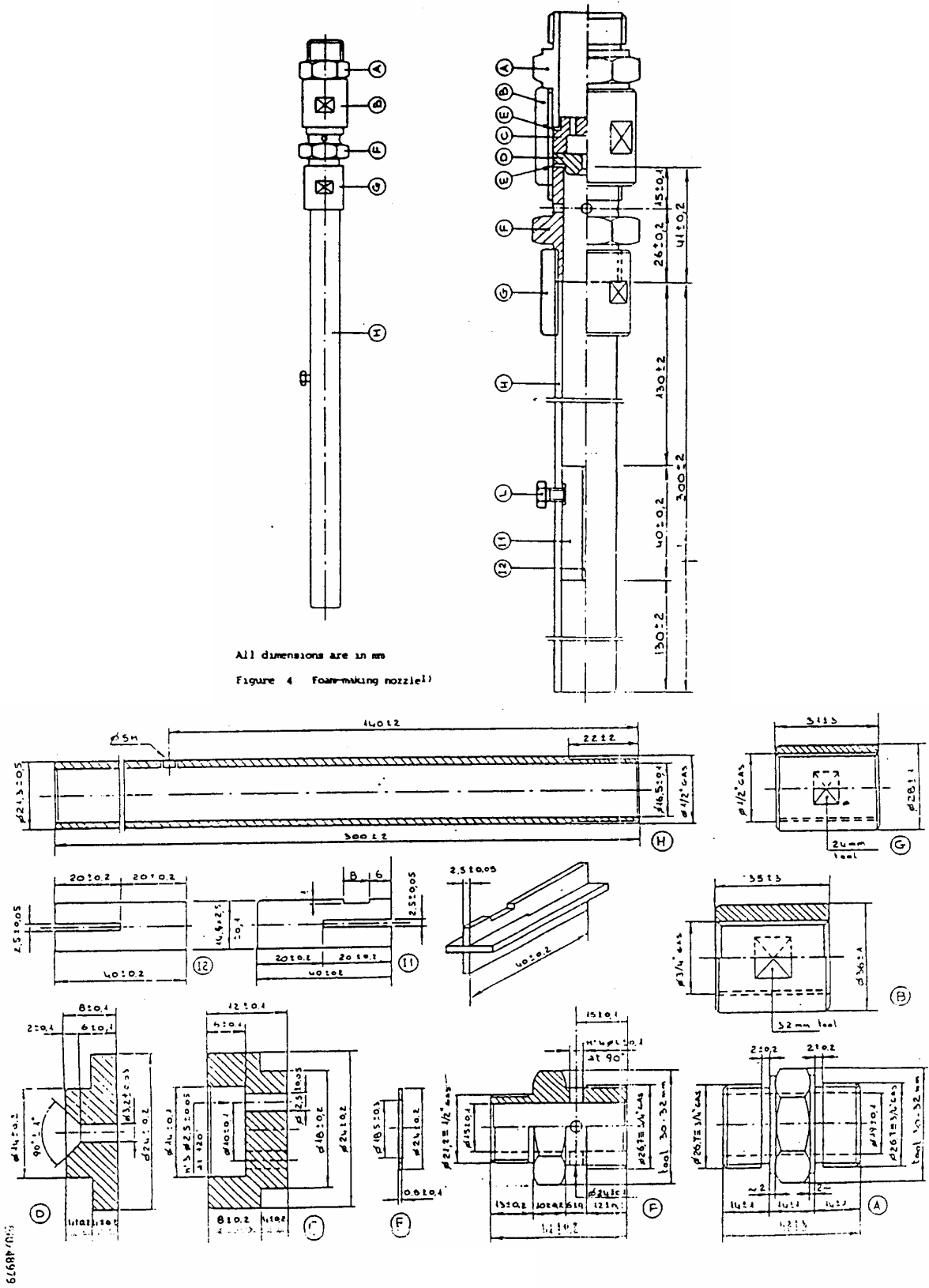

Figure 4 – Foam making nozzle